

Maximum flexibility, security and energy-efficiency with the roller shutter systems for windows, patio doors and (lifting-)sliding doors

heroal roller shutter systems



heroal

Extremely robust and energy-efficient: heroal roller shutter systems

Premium materials, solutions that are technically coordinated down to the last detail and a wide range of design options are what distinguish the efficient heroal system solutions. For decades, heroal has been a reliable partner for architects, planners, fabricators and builders with innovative aluminium and aluminium composite solutions for the building shell.

Architects and planners value the huge variety of design options, while heroal specialist partners benefit from the economical and efficient heroal system solutions and builders are able to realise their specific preferences with a reliable system.

heroal roller shutter systems impress across the board – even when compared against roller shutters made from other materials: the aluminium and stainless steel materials used make heroal roller shutter systems extremely durable, low-maintenance and robust. They enable opening widths that are simply not possible with other materials – without having to forego high wind load resistance. Depending on the version, they offer fantastic burglary resistance up to resistance class RC 3. They are hail- and weather-resistant, increase soundproofing and are particularly quiet to operate. heroal roller shutter systems also impress when it comes to energy-efficiency, as they have a positive impact on a building's heat insulation. What's more, a wide range of permanently colourfast coatings provide a huge amount of design freedom.



Roller shutter systems [Page 04](#)

Roller shutter slats [Page 06](#)

Panel systems [Page 10](#)

End slats and guide rails [Page 16](#)

Security roller shutters [Page 18](#)

Insect screen system [Page 20](#)

Finished curtain [Page 21](#)

Colour selection [Page 22](#)

heroal roller shutter systems

Maximum flexibility, security and energy-efficiency with aluminium and stainless steel roller shutters

heroal roller shutter slats

are available in the Mini, Maxi and Safe versions to provide the matching solution for every requirement. The huge selection of different systems, high-quality materials and excellent design freedom means that there are virtually no limits to the potential applications.

> Page 06

heroal panel systems

offer maximum flexibility for every installation situation and every application with a variety of shapes, sizes and colours - as well as providing exceptional stability.

> Page 10

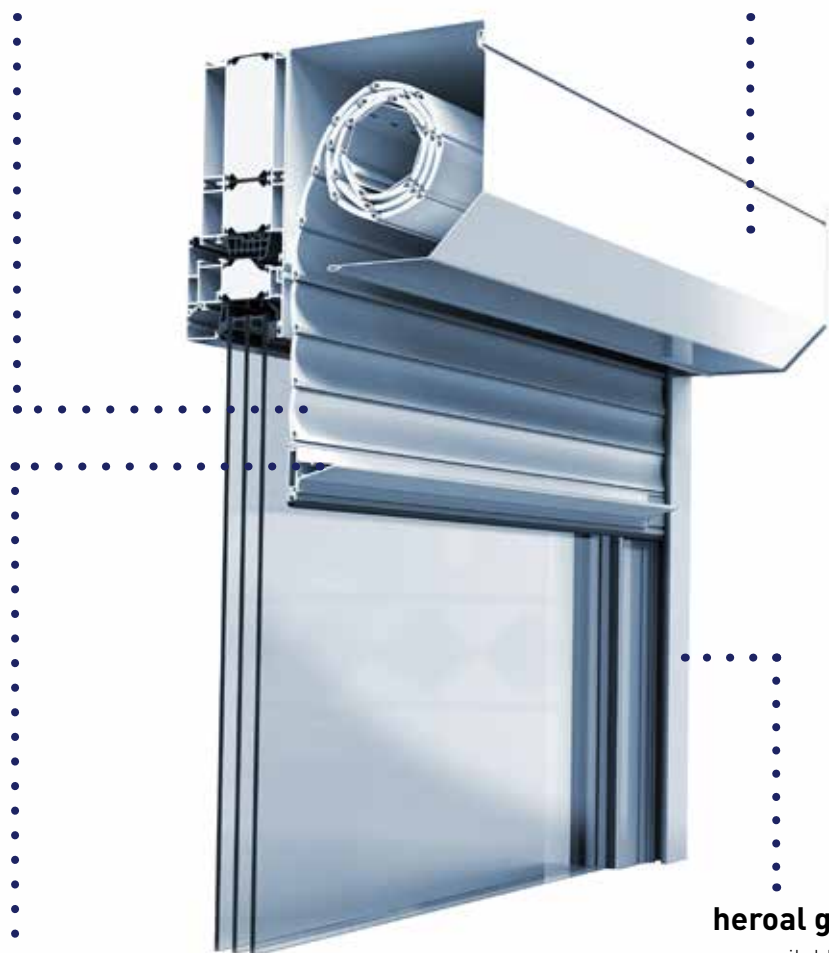

heroal guide rails

are available in different encroachment and insert versions as well as with and without a distance to the window. They can be combined with various panels and roller shutter slats and are also available for heroal insect screen systems.

> Page 16

heroal end slats

are available in a range of versions to provide the right end slat for every roller shutter slat. When it comes to design, the heroal portfolio offers smooth as well as angled end slats.

> Page 16

heroal roller shutter systems

As the inventor of the foamed "heroal Selecta" roller shutter slat in 1969, the family-run company is a pioneer that set a new benchmark in the industry. Ever since, heroal has continuously expended its assortment of high-quality and versatile roller shutter systems. With its broad portfolio of roller shutter slats, front-mounted and flush-mounted panel systems, guide rails and end slats, heroal has the perfect solution for virtually every new-build and renovation project.

Efficient fabrication and installation

When developing and advancing roller shutter systems, time-saving and easy fabrication and installation are the top priority for heroal. This is made possible through standardised processes, the use of common parts and well-designed construction details. For maximum flexibility in fabrication, heroal roller shutter systems are available as systemware, finished curtains or as prefabricated heroal Ready finished elements.

Greater comfort and security

heroal roller shutter systems provide effective protection from glare, heat and prying eyes. They support thermal insulation in the summer and winter, which helps to save energy. heroal roller shutter systems also help to reduce the noise level. The option of integrating an insect screen as well as various types of operation - from manual to motor-operated as well as the connection to a Smart Home system - helps to provide even greater comfort. Where greater security is required, heroal roller shutter systems are also available as burglary resistant variants.

Outstanding quality for versatile applications

heroal roller shutter systems impress with their exceptional durability and weather resistance. The roller shutter slats that are roll-formed in our in-house production department are manufactured from extremely robust, recycled aluminium. What's more, heroal roller shutter slats are also available in stainless steel. Thick walls and medium- to high-density foam filling make heroal roller shutter slats extremely stable while also ensuring optimal winding behaviour so that even large elements only require small box sizes.

Design freedom

There are virtually no limits to the design of heroal roller shutter systems. The high-quality heroal hwr powder coating of the extruded components as well as the durable heroal 2-layer thick coating of the roll-formed components make heroal roller shutter systems perfect for individual designs. Both types of coating are perfectly matched for building shells that are seemingly cast from the same mould. Panel box systems available in different designs complete the design options. These features turn heroal roller shutters into an aesthetic highlight on any building.



heroal roller shutter slats

Mini roller shutter slats

Mini roller shutter slats are roller shutter slats with coverage widths of 32 to 42 mm in the heroal portfolio. Thanks to the high-quality aluminium alloy and outstanding wind-resistance, heroal Mini roller shutter slats are also suitable for use in large elements. What's more, they set themselves apart with their high-quality and durable coating: the heroal 2-layer thick coating is even certified for use on ships and is available in numerous colours. As an additional design element, heroal

Mini roller shutter slats are available with and without light slits. The comprehensive portfolio contains the perfect Mini roller shutter slat for every application. For instance, the heroal RS 37 roller shutter slat impresses with its exceptional winding properties, while the RS 37 SL (Safe Light) roller shutter slat was developed for increased safety requirements thanks to the greater thickness of the materials used.



heroal RS 32



heroal RS 37



heroal RS 37 SL



heroal RS 38



heroal RS 41



heroal RS 41 SW



heroal RS 42

heroal roller shutter slats

Maxi roller shutter slats

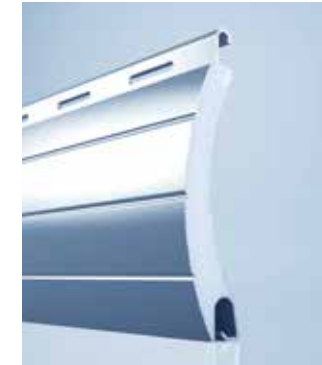

heroal RS 52



heroal RS 55 SL

The heroal Maxi roller shutter slats are slat variants with coverage widths of 52 or 55 millimetres, which are particularly popular in the new-build segment. They are ideal for large curtains and impress with outstanding wind load properties. The huge selection of colours provides countless options for designing the Maxi roller shutter slats.

heroal roller shutter slats

Safe roller shutter slats



heroal RS 37 RC 2

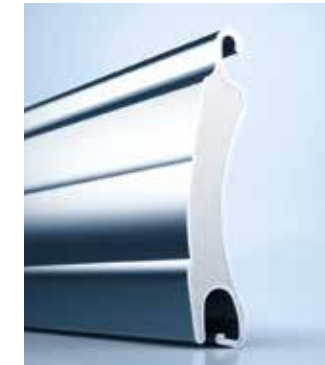

heroal RS 37 RC 3

The heroal Safe roller shutter slats are used in security roller shutters. They impress with their outstanding stability thanks to exceptionally robust wall thicknesses and high-density foam filling. This also makes them suitable for large roller shutter curtains. The different variants with coverage widths of 37 and 53 millimetres support flexible applications. When used in the heroal Safe porch unit, they are certified in line with RC 2 or RC 3 as per DIN 1627.



heroal RS 53 RC 2

heroal roller shutter slats

System features and comparison

	heroal Mini roller shutter slats							heroal Maxi roller shutter slats		heroal Safe roller shutter slats		
Description	heroal RS 32	heroal RS 37	heroal RS 37 SL	heroal RS 38	heroal RS 41	heroal RS 41 SW	heroal RS 42	heroal RS 52	heroal RS 55 SL	heroal RS 37 RC 2	heroal RS 37 RC 3	heroal RS 53 RC 2
3D illustration												
2D illustration												
Version	Aluminium	Aluminium	Aluminium	Aluminium	Aluminium	Aluminium	Aluminium	Aluminium	Aluminium	Aluminium	Stainless steel	Aluminium
Coverage width/nominal thickness (mm)	32/8.5	37/8.0	37/9.5	38/9.0	41/8.5	41/8.0	42/9.3	52/13.5	55/14.0	37/9.5	37/9.5	51/14.0
Max. width/height (mm)	3,500/3,500	3,000/3,500	4,000/4,000	3,700/3,800	3,500/3,500	3,500/3,500	3,500/3,500	4,500/3,800	5,000/4,000	4,200/4,000	5,000/4,000	5,500/4,000
Max. area (m ²)	7.5	6.2	9.0	8.0	7.0	7.0	7.0	9.0	12.0	10.5	12.0	16.5
Finished curtain weight (kg/m ²) ¹⁾	4.8	3.5	5.9	4.5	3.7	3.7	3.9	4.0	5.0	8.8	15.0	10.5
With/without light slits	• / •	• / •	• / •	• / •	• / •	• / •	• / •	• / •	• / •	• / •	- / •	• / •
Wind resistance class ²⁾	2	1	4	3	2	2	2	4	5	4	6	6
Optimised noise insulation (dB) ³⁾	+10	+10	+10	+10	+10	+10	+10	+10	+10	+10	+10	+10
Foam filling (medium-density/high-density)	• / -	• / -	• / -	• / -	• / -	• / -	• / -	• / -	• / -	- / •	- / •	- / •
Hail impact class ⁴⁾	4	4	5	4	4	4	3	5	5	7	7	7
Burglary resistance (RC) ⁵⁾	-	-	SL	-	-	-	-	-	SL	RC 2	RC 3	RC 2
Roller shutter slats for 1 metre curtain height	32	27	27	27	25	25	24	20	18	27	27	20
2-layer thick coating	•	•	•	•	•	•	•	•	•	•	-	•

1) Weight incl. end slat

2) For 2,700 mm element width and a guide with 25 mm insertion depth, for heroal RS 37 RC 2 and heroal RS 37 RC 3 with 40 mm insertion depth, for heroal RS 52 RC 2 and heroal RS 52 RC 3 with 51 mm insertion depth

3) With a 100 mm air gap between the roller shutter curtain and the insulating glass pane, the noise insulation value increases by up to 10 dB

4) Hail impact class as per VKF test regulations no. 02

5) SL, the roller shutter slat satisfies technical guideline TR 111 published by the Bundesverband für Rollläden und Sonnenschutz association for roller shutters and sun protection BVRs RC 2/RC 3, the roller shutter slat satisfies DIN 1627 RC 2/RC 3, the roller shutter slat satisfies DIN 1627



heroal panel systems

heroal FMR and heroal GKSE roll-formed front-mounted panel systems

heroal front-mounted panel systems are ideal for retrofitting in the window reveal or on the curtain wall. They are easy to install, improve heat insulation by eliminating thermal bridges and their soundproofing ensures greater comfort. Thanks to their straight-edged design and fantastic design freedom, they can be harmoniously integrated into the building shell. The heroal FMR roll-formed flush-mounted boxes are available with a 20°, 45° and 90° chamfer as well as quarter- and half-round versions to provide distinct optical highlights and increase the incidence of light inside the building as required.

For instances in which specific requirements are placed on stability, heroal developed the heroal GKSE front-mounted box. heroal GKSE consists of, among other things, panels with stable strip thicknesses manufactured from a high-quality aluminium alloy as well as panel caps made from robust die-cast aluminium. This makes heroal GKSE the perfect solution for particularly large roller shutter and roller door elements.



heroal FMR 20°



heroal FMR Q



heroal FMR 45°



heroal FMR HC



heroal FMR 90°



heroal GKSE

heroal panel systems

heroal FME extruded front-mounted panel systems

The heroal FME extruded front-mounted panel system is the perfect solution in cases where greater requirements are placed on stability and security. heroal FME is available in different versions: in a cubic design with 20°, 45° and 90° chamfer as well as in a half-round design. The large selection of colours offers countless opportunities for customisation. Installed in the window reveal or on the curtain wall, the front-mounted panels can either subtly blend in or act as a visual

highlight in the building shell. No direct connection to the interior is necessary, which prevents thermal bridges. The variant with sliding close enables easy removal if maintenance becomes necessary. The inspection panel can be fastened in a decorative strip on the side. All screw connections are concealed to create a particularly attractive look.



heroal FME 20°



heroal FME HC



heroal FME 45°



heroal FME 20° SC, sliding close detail



heroal FME 90°



heroal FME 90° SC, sliding close detail

heroal panel systems

heroal FMB flush-mounted panel system and heroal FMS security panel system

Invisibly integrated in the curtain wall, the heroal FMB flush-mounted panel systems combine a harmonious curtain wall appearance with all the functional benefits. The huge selection of plaster-base profiles enables the versatile use of heroal FMB flush-mounted panels in new-build as well as renovation projects. As the flush-mounted panels are fully integrated into the curtain wall, there are no thermal bridges to the interior. heroal FMB is installed in the lintel. A stable, extruded inspection panel is always accessible from the outside.

The heroal FMS extruded security panel system offers exceptional burglary resistance thanks to its thick walls, security catches that can only be opened with a special key and steel panel caps, among other features. They can be used to install security roller shutters in resistance classes RC 2 and RC 3.



heroal FMB 20°



heroal FMS 45°



heroal FMB 45°



heroal FMB 90°

heroal panel systems

System features and comparison

Version	heroal FMR roll-formed front-mounted panel systems					heroal FME extruded front-mounted panel systems				heroal FMB flush-mounted panel systems			Security panel systems	
Description	heroal FMR 20°	heroal FMR 45°	heroal FMR 90°	heroal FMR Q	heroal FMR HC	heroal FME 20°	heroal FME 45°	heroal FME 90°	heroal FME HC	heroal FMB 20°	heroal FMB 45°	heroal FMB 90°	heroal FMS 45°	heroal GKSE
3D illustration														
2D illustration														
Box sizes	125, 137, 150, 165, 180, 205	125, 137, 150, 165, 180, 205, 230	125, 137, 150, 165, 180, 205	137, 150, 165, 180, 205	137, 150, 165, 180, 205	125, 137, 150, 165, 180, 205 ³⁾	125, 137, 150, 165, 180, 205	125, 137, 150, 165, 180, 205 ³⁾	137, 150, 165, 180, 205	125, 137, 150, 165, 180, 205	137, 150, 165, 180, 205	125, 137, 150, 165, 180, 205	205	205, 230, 254, 300
Number of panel parts	2	2	2	2	2	3/4	3	4	3	2	2	2	3	2
Insect screen can be integrated	•	•	•	•	•	•	•	•	•	•	•	•	-	-
Anti-push-up device (can be integrated)	•	•	•	•	•	•	•	•	•	•	•	•	•	•
Burglary resistance (RC) ¹⁾	-	-	-	-	-	SL	SL	SL	SL	SL	SL	SL	RC 3	-
Hail impact class	6	6	6	6	6	7	7	7	7	-	-	-	7	5
hwr powder coating	-	-	-	-	-	•	•	•	•	•	•	•	•	-
2-layer thick coating ²⁾	•	•	•	•	•	-	-	-	-	-	-	-	-	•
Eloxal coating	-	-	-	-	-	-	-	-	-	-	-	-	-	-
heroal SD	•	•	•	•	•	•	•	•	•	•	•	•	•	•
Les Couleurs® Le Corbusier	•	•	•	•	•	•	•	•	•	•	•	•	•	•

1) Applies for the entire system, SL, the roller shutter slat satisfies technical guideline TR 111 published by the Bundesverband für Rollläden und Sonnenschutz association for roller shutters and sun protection BVRs RC 2/RC 3, the roller shutter slat satisfies DIN 1627

2) heroal FMR panel systems can be coated with the heroal RAL hwr powder coating as well

3) The heroal FME 20° and heroal FME 90° panel systems with sliding close (SC) are available in box sizes 137, 150, 165, 180

heroal end slats

Versatile and tough



Top: smooth Maxi end slat, bottom: Mini angled end slat

The end slats manufactured from extruded aluminium are available as smooth end slats (with and without rubber seal), angled end slats and Safe end slats in a wide range of versions. Depending on requirements, a concealed backstop, stopping block, or backstop with angled end slat can be selected. The backstop function ensures that the end slat is not drawn into the panel box. For motors with automatic end position detection for torque, it also serves as the top end position. The optional flat steel slide-in unit increases the weight during manual operation. Different end slats for Mini and Maxi slats ensure a highly durable and tight-closing, heat insulating roller shutter. All end slats are coated with highly weather-resistant heroal hwr powder coating, which is available in countless shades.

heroal guide rails

Secure solutions for all installation situations



heroal guide rail

heroal offers a huge variety of guide rails for heroal Mini, Maxi and Safe roller shutter systems as well as integrated insect screen systems for designing the perfect solution for every installation situation. The heroal portfolio offers solutions with different chamber depths that can be used to respond to different wind load class requirements. What's more, the centre columns as well as the guides with distance are available for selection. The stable extruded rails made of high-quality aluminium are equipped with rolled-in inserts to ensure maximum curtain stability. Weather strips made from soft PVC, hard PVC or brush inserts ensure a reliable, quiet curtain operation. The extensive selection of different guide rails as well as the highly weather-resistant heroal hwr powder coating provides maximum design freedom.

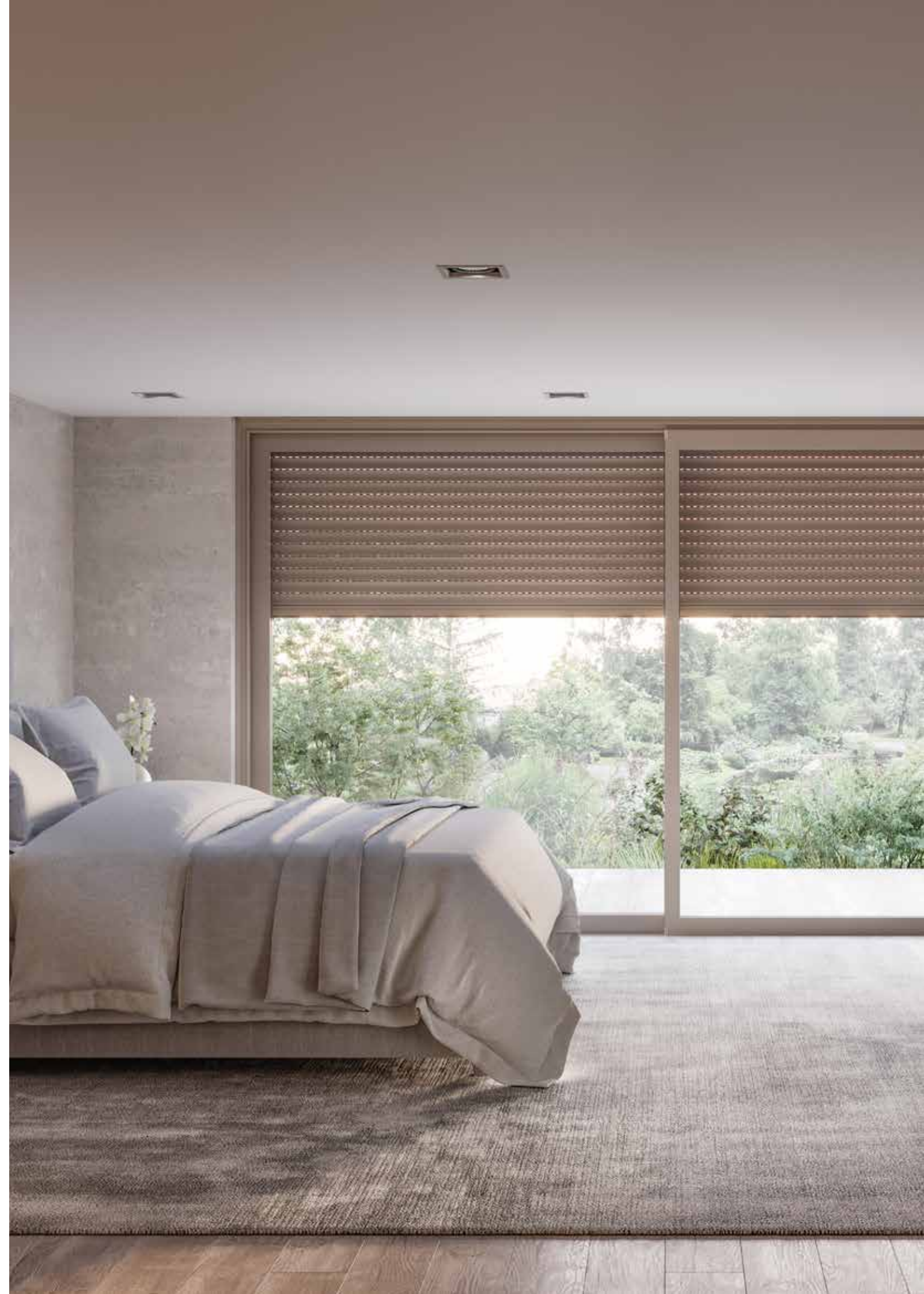

heroal security roller shutters

heroal Safe security roller shutters

The heroal Safe security roller shutter system satisfies the extremely strict requirements for security roller shutters in resistance classes RC 2 and RC 3 as per DIN EN 1627. This is made possible by the smart construction together with the

burglary resistant components as well as the extremely robust roller shutter slats, extruded components and functionalities such as the integrated anti-push-up device.

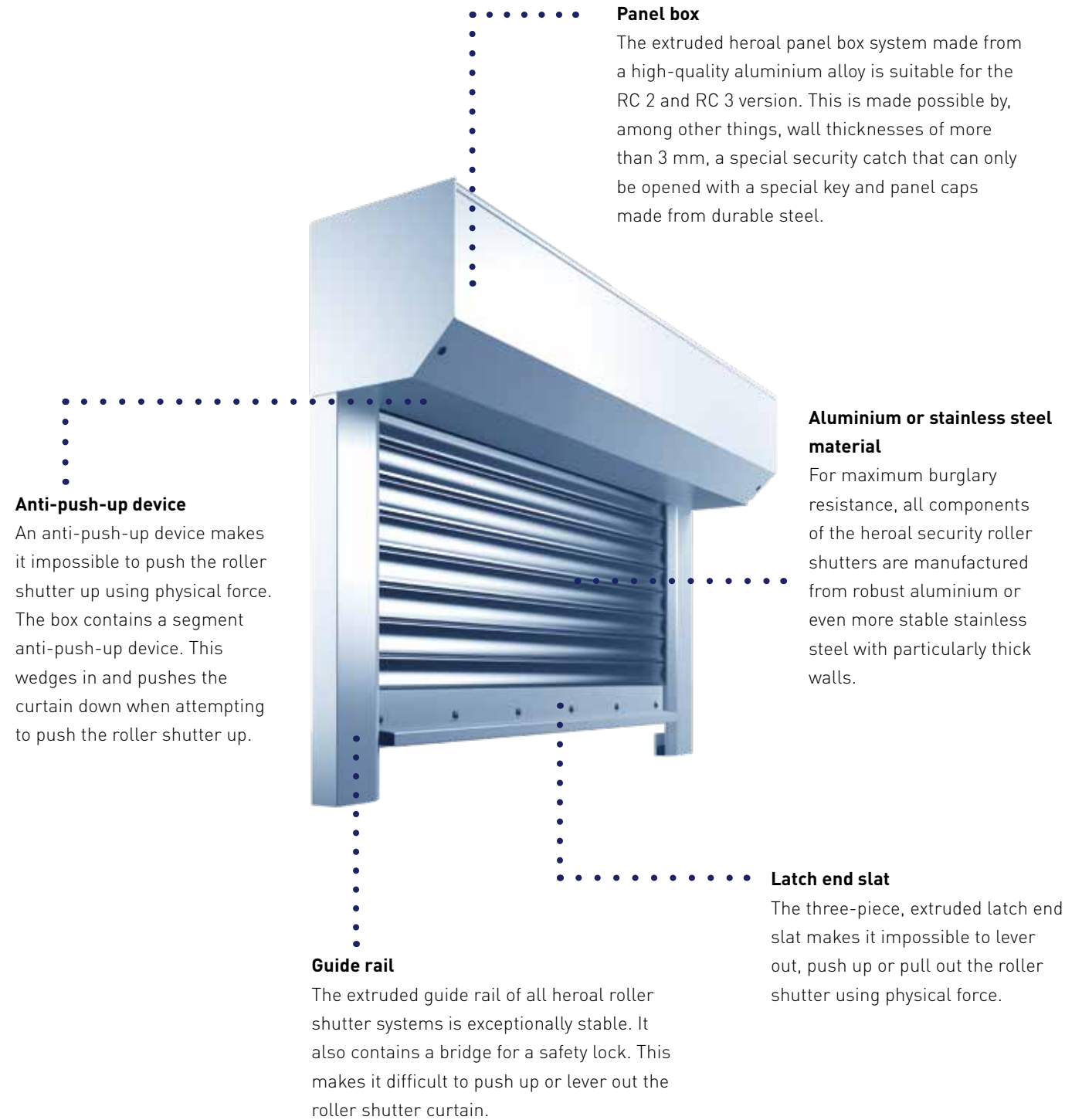

Reinforced guide rail with S-locking curtain

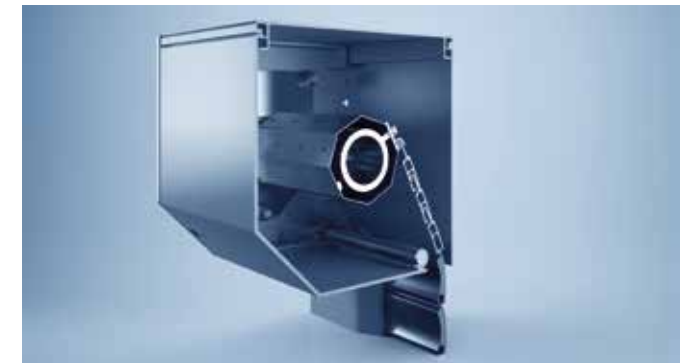

Anti-push-up device



heroal RS 37 RC 3, heroal FMS



End slat with integrated latch

heroal security roller shutters

heroal Safe Light security roller shutters



heroal RS 37 SL with Click Stop system

The heroal Safe Light aluminium system closes the gap between conventional roller shutter systems and the certified security roller shutters in resistance classes RC 2 and RC 3. The "Click Stop" anti-push-up device makes it difficult to push up or lever out the roller shutter curtain. An extruded angled end slat as well as a robust guide rail make the roller shutter even more secure. For instance, burglary-resistant heroal RS 37 SL roller shutter slats with a coverage width of 37 mm or heroal RS 55 SL with a coverage width of 55 mm can be selected.

The heroal Safe Light security roller shutter was the first solution to be awarded the RSQ seal and satisfies BVRS guideline TR 111 in the area of burglary resistance.



Insect screen system

heroal IS



The heroal IS insect screen systems is suitable for integration in heroal roller shutter systems with Mini roller shutter slats and is installed directly in the roller shutter's panel box system. Panel boxes with offset pins support the optimal utilisation of the winding space in the panel box. An end slat latch ensures the clean fastening of the heroal IS insect screen in its lower end position. The comfortable, almost automatic raising of the insect screen textile is made possible by an integrated spring mechanism. A grip end slat provides additional assistance with operation.

	heroal IS Classic roller blind	heroal IS Light roller blind
Fabric type	Fibreglass fabric PVC coated	Fibreglass fabric PVC coated
Features	Suitable for all standard installation situations	Improved light and air passage
Translucence	Standard	+ 45%
UV stability	UV-stable	UV-stable
Pollen protection	Low	Low

Features	heroal IS Classic roller blind	heroal IS Light roller blind
Mesh size	1.29 - 1.13 mm	1.18 - 1.04 mm
Application	heroal IS heroal IS integrated heroal IS KIS	heroal IS heroal IS integrated heroal IS KIS
Award	"Der blaue Engel"	"Der blaue Engel"
Available colours	Grey	Anthracite grey
Fire protection	Self-extinguishing	Self-extinguishing

heroal finished roller shutter curtain

Prefabricated finished roller shutter curtain



For maximum flexibility, rapid availability as well as easy and time-saving manufacturing, heroal roller shutter slats are also available as prefabricated finished roller shutter curtains. In this case, the roller shutter curtain is locked with latches as standard. Delivery without latches is possible upon request. Mounts for attachment on the axle can also be supplied upon request. A huge range of roller shutter slat systems and various end slats from the heroal portfolio are available for the finished roller shutter curtains. A wide selection of shades are available for individual customisation. heroal finished roller shutter curtains can be quickly and easily ordered using the heroal Business configurator.

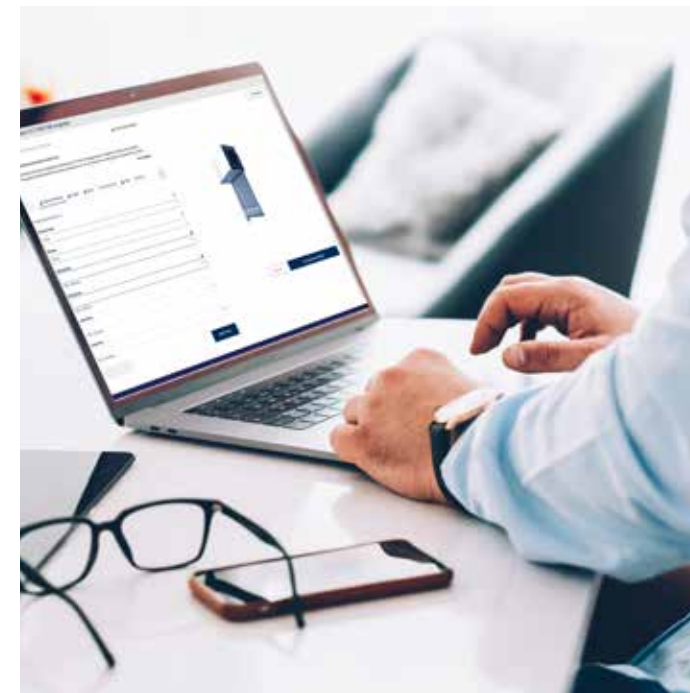

Finished elements that are easy to configure and order

The heroal Business configurator in the heroal Communicator lets you quickly and easily configure finished roller shutter and sun protection elements and order systemware and finished roller shutter curtains. Create a customised product configuration and you will quickly receive an offer for yourself as well as an offer that you can forward directly on to your customer. That's how the heroal Business configurator supports an optimised order process. Potential errors are avoided and the automated order and offer creation simplifies the processes. In addition, all the data is always up to date. Systemware and finished curtains can also be ordered.

Colour selection

heroal Mini, Maxi and Safe roller shutter slats



Not all Mini, Maxi and Safe roller shutter slats are available in all colours. You can check the availability for each slat in order and production catalogue 87100.

The illustrations of the colours may differ slightly from the original products.

heroal



simply better *spaces for life*

As a manufacturer of aluminium system solutions for roller shutters, sun protection, roller doors, windows, doors, sliding doors, curtain walls and patio roofs, heroal is an international market leader, supporting high-quality residential and commercial construction projects worldwide. heroal products are developed and manufactured in Germany and set themselves apart with their premium quality and exceptional performance features. As a result, the innovative system solutions contribute to greater sustainability, security, comfort and architectural freedom for both current and future building projects and impress with simple and efficient planning and fabrication by heroal specialist partners.

Roller shutters | Sun protection | Roller doors | Windows | Doors | Sliding doors | Curtain walls |
Patio roofs

heroal – Johann Henkenjohann GmbH & Co. KG

Österwieher Str. 80 | 33415 Verl (Germany) | Tel. +49 5246 507-0 | Fax +49 5246 507-222 | www.heroal.com

Article no. 88150 30 02 | 01.2024